

# VISTA SERIES

**STANDARD CONSTRUCTION:**

**OUTRIGGER & BRACKET:**

- 0.25"(6.35mm) Aluminum (standard)
- 0.375"(9.53mm) Aluminum (optional)

**BLADES:**

0.25"(6.35mm) Aluminum Rectangular Tubes  
 2"(51mm) (W) X 6"(152mm) (H)  
 on approximately 6"(152mm) centers.

**MOUNTING BRACKETS:**

0.25"(6.35mm) Aluminum

**FINISH:**

mill aluminum (std.)

**MAXIMUM SIZE:**

Length 96"(2438mm) x Projection 96"(2438mm) (max.)

**OPTIONAL FINISHES:**

- Powder Polyester TGIC** (2 coats) baked on at 410°F(210°C) -2.5 to 3.5 mils Meets AAMA-2603 Standards
- Powder Super durable polyester** (2 coats) baked on at 410°F(210°C) -2.5 to 3.5 mils Meets AAMA-2604-05 Standards
- Acrylic baked enamel** (ACRA-BOND® ULTRA) by AkzoNobel baked on at 350°F(176°C) -0.8 to 1.2 mils dry Meets AAMA-2603 Standards
- Kynar®** (ALUM\*A\*STAR®) 2 coats by AkzoNobel baked on at 450°F(232°C) -1.2 to 1.6 mils dry Meets AAMA-2604-05 Standards
- Kynar 500®** or HYLAR® 5000 70% TRINAR® (2 coats) by AkzoNobel baked on at 450°F(232°C) -1.2 to 1.6 mils dry, Meets AAMA-2605-05 Standards
- Kynar 500®** or HYLAR® 5000 (70% Tri-Escent II) (2 coats) by AkzoNobel, a superior finish to other metallic or anodized finishes. A blend of mica, ceramic, and inorganic pigments creates subtle yet dazzling design that goes beyond metallic color without the requirement of a clear coat. 14 standard colors - custom colors available. Baked on at 415°F(213°C) -1.4 to 1.8 mils dry, meets AAMA 2605-05.
- Clear Anodize Match** (paint meets AAMA 611)
- Integral Color Anodize Match** (paint meets AAMA 611)
  - Clear coat available for all above finishes.
  - Hylar® 5000 is a registered trademark of Solvay Solexis, Inc.
  - Kynar® 500 is a registered trademark of Arkema.
  - ALUM\*A\*STAR® 50 and TRINAR® are registered trademarks of AkzoNobel
  - ACRA-BOND® ULTRA is a registered trademark of AkzoNobel

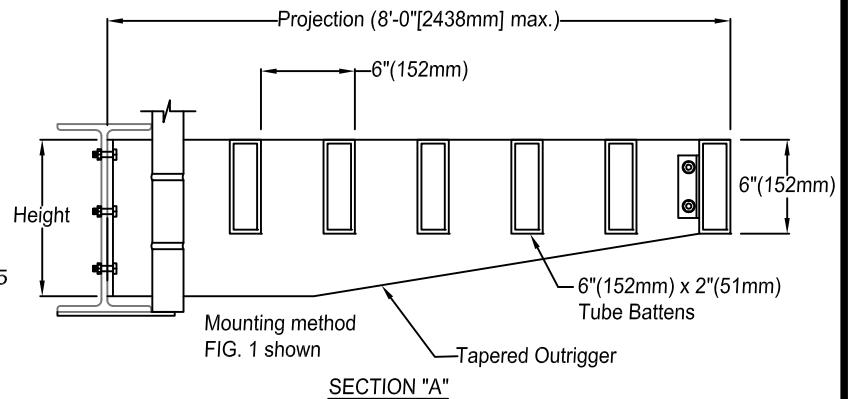
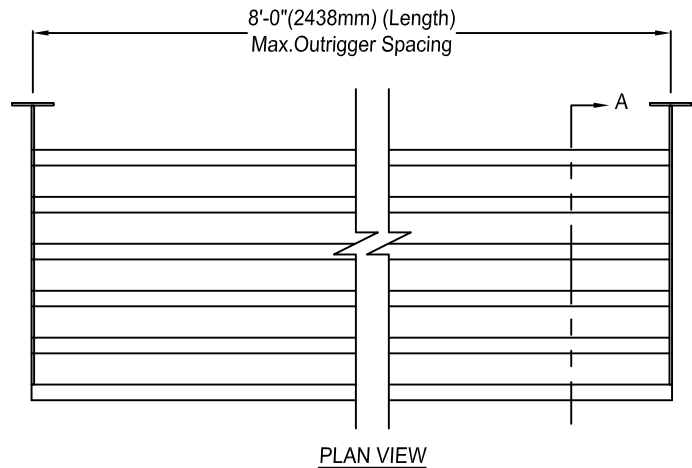

3 part specifications - see online at [www.unitedenertech.com](http://www.unitedenertech.com)



Due to continuing research, United Enertech reserves the right to change specifications without notice.

QUANTITY	LENGTH	HEIGHT	PROJECTION	TAG



3005 South Hickory Street  
 Chattanooga, Tennessee 37407  
 Tel: (423) 698-7715  
 Fax: (423) 698-6629  
[www.unitedenertech.com](http://www.unitedenertech.com)

**VISTA SERIES**

DRAWN BY: GDR	DATE: 1-12-10	REV. DATE: 5-8-13	REV. NO. 5	APPROVED BY: BGT	DWG. NO.: <b>C-14</b>
------------------	------------------	----------------------	---------------	---------------------	--------------------------